

## RV/RF 20/40



Kongskilde Rotary Valves, type RV and RF, are suitable for feeding of granulates, (granules, pellets, flakes, small moulded products

etc.) either into a pressurised pneumatic conveying line or as a metered feed to a subsequent process.

The valves' design ensures minimal pressure losses when introducing products into a pressurised conveying line.

# RV/RF 20/40

Kongskilde Rotary Valves contain a slow rotating, enclosed, six chambered rotor. Each of the chambers' divisions is fitted with a wear-resistant polyurethane blade, which forms an air-tight seal with the precision-made valve housing, preventing any material from jamming the rotor.

RV and RF Rotary valves are suitable for many differing applications involving the controlled delivery of material to a conveying system or to a production process.

## Typical Applications

1. Metered feed
2. Negative pressure, (vacuum), conveying system
3. Dosing
4. Positive pressure conveying system
5. Suction/blowing system (utilising positive and negative pressure conveying)

1. Metered feed

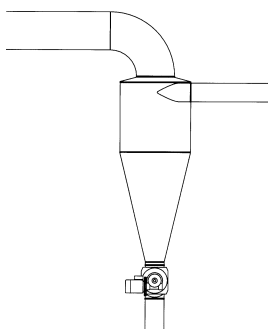

3. Dosing

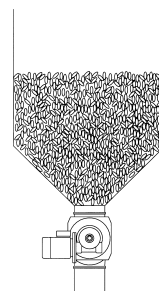

4. Positive pressure conveying system

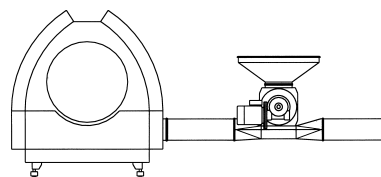

5. Combined negative and positive pressure conveying

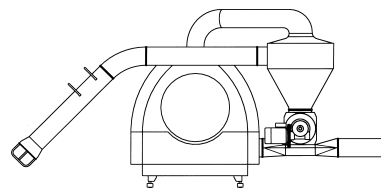

2. Negative pressure, (vacuum), conveying system

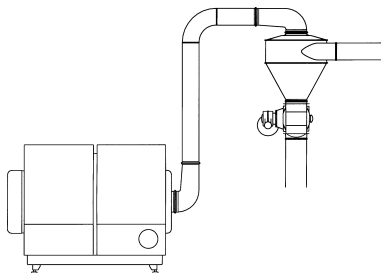

## Two Types

To meet the demands of industry Kongskilde has developed two versions of the Rotary valve - the RV and the RF.

The RV version is specifically designed to handle granular materials with minimum air losses through the valve.

The design of the RF version allows it to handle flake material, such as might come from grinders.

### RV

The RV rotor is suited to handling granular material. Polyurethane chamber blades form an air-tight seal with the rotor housing, reducing air leakage to a minimum.

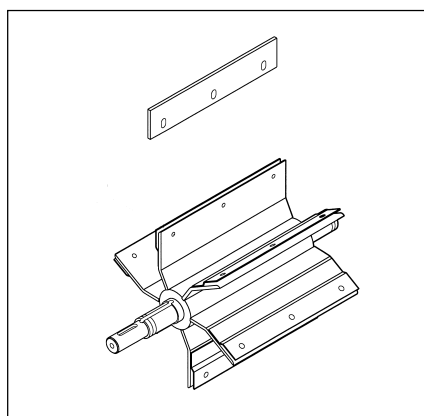

### RF

The RF rotor is able to handle flake materials. Flexible polyurethane blades are fitted to either side of the stubs of the chamber division walls, to prevent any thinner materials from jamming the rotor during operation.

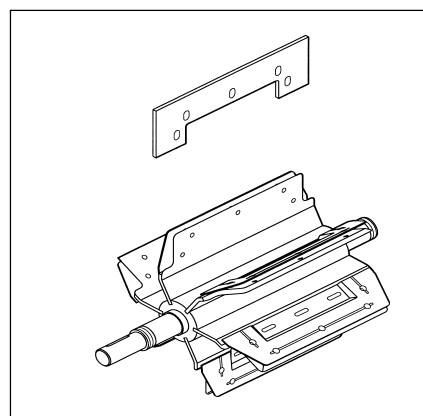

## Technical Data

As standard, the RV/RF 20 is available with any one of four geared motors. The gearing selected should match the application to ensure optimum operation.

Standard versions of the RV/RF 40 provide a choice of three rotor speeds.

A variable speed range for both 20 and 40 versions can be obtained by use of an electrical speed controller (inverter).

As standard, all rotary valves are fitted with "sealed for life" bearings.

## RV/RF 20

Rotary Valve rpm	Ratio	Motor kW	Motor	Motor rpm	Weight in kg w/motor
70	1:20	0.75	IEC 80 B5	1400	40
43	1:32	0.75	IEC 80 B5	1400	40
35	1:40	0.55	IEC 80 B5	1400	39
22	1:70	0.37	IEC 71 B5	1400	36

## RV/RF 40

Rotary Valve rpm	Ratio	Motor kW	Motor	Motor rpm	Weight in kg w/motor
70	1:20	2.2	IEC 90 B5	1400	97.5
56	1:25	1.5	IEC 90 B5	1400	95
35	1:40	1.1	IEC 90 B5	1400	92

## Capacity

The degree to which each chamber of the rotary valve will be filled will depend upon material density. As a guideline a chamber will be 85% filled if the material is a free-flowing granulate with a bulk density of 670kg/m<sup>3</sup>. Filling efficiency increases as rpm decrease.

Valve capacity is reduced when handling light, less free-flowing materials. For such applications Kongskilde recommends a maximum rotor speed of 50 rpm.

### RV/RF 20

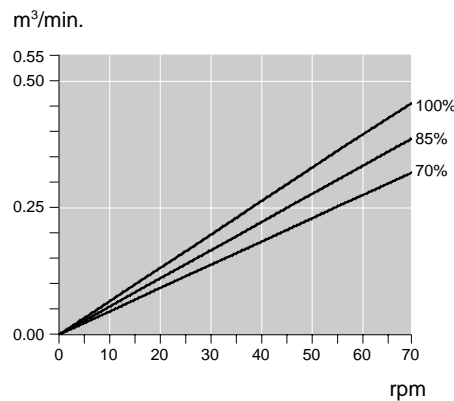

### RV/RF 40

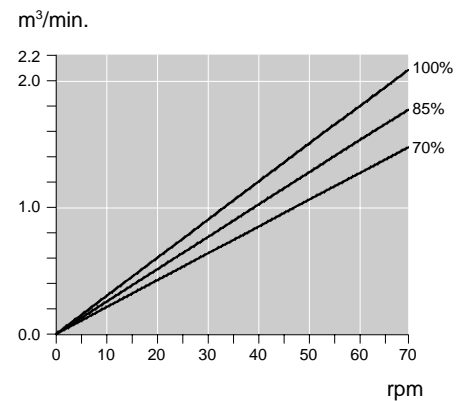

## Leakage Curves

Kongskilde Rotary Valves are carefully designed to minimise air leakage, but this can never be avoided completely, due to the pressure differential across the valve. On the outlet side compressed air will flow into the valve chambers, and escape on the inlet side. *This resultant air stream can severely restrict material flow if the valve inlet is sealed to the feed line.*

Please ask Kongskilde for further details.

### RV/RF 20

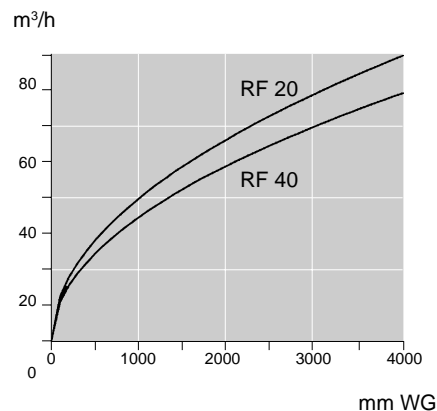

### RV/RF 40

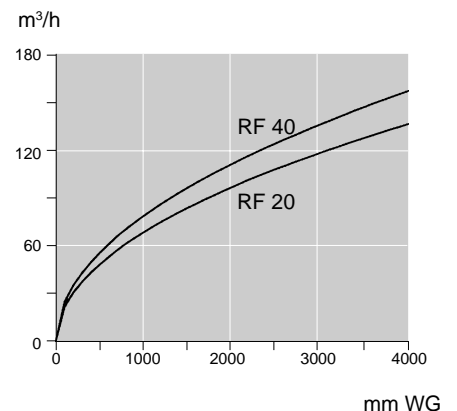

# Dimensions

## RV/RF 20

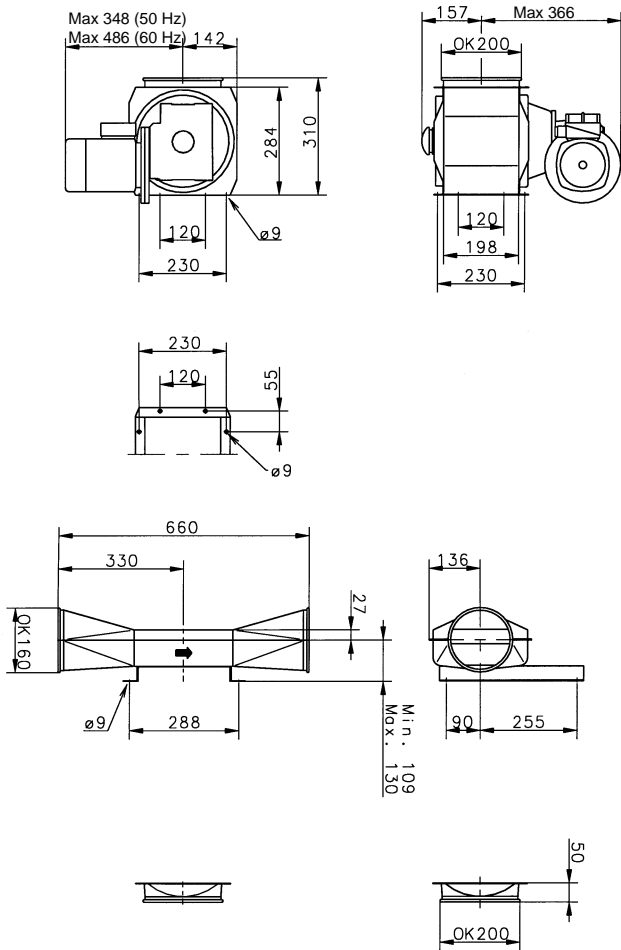

1. RV/RF 20
2. Outlet, horizontal connection
3. Outlet, vertical connection

## RV/RF 40

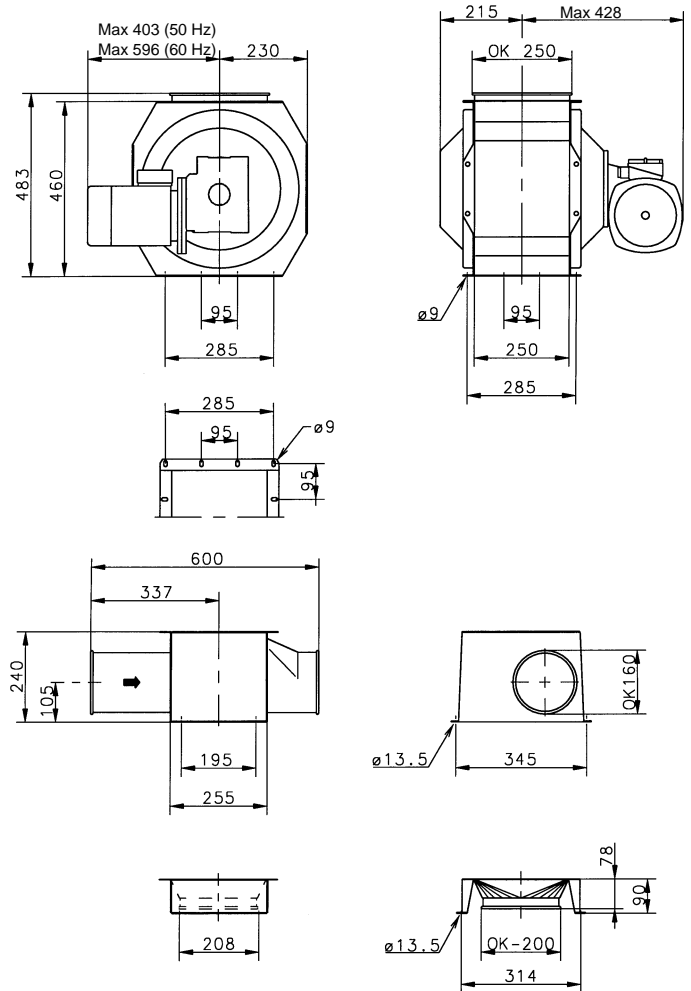

1. RV/RF 40
2. Outlet, horizontal connection
3. Outlet, vertical connection

RV/RF 20/40 accessories include an inlet hopper with shutter.  
Please do not hesitate to contact Kongskilde for further information.



Kongskilde Industries A/S  
DK-4180 Sorø, Denmark  
Tel. +45 57 86 50 00  
Fax +45 57 86 51 00  
E-mail: mail@kongskilde.com  
www.kongskilde.com