



Valves

Handling the world's dry bulk solids®

VORTEX® CLEAR ACTION GATE™

The patented Vortex® Clear Action Gate™ is a problem solver specifically designed for demanding dry bulk material applications. Patented design concepts, specialized machining, and materials of construction produce a high quality yet economical valve for use in pneumatic conveying systems up to 15 PSIG (1 Barg). Traditional knife gates or butterfly valves are designed to handle gases and liquids, not dry materials. These valves rely on soft rubber seals, which erode or tear away during use, allowing leakage of air and material through the valve or into the plant's atmosphere. This causes the frequent need for valve maintenance, production inefficiencies, and unsanitary plant environments. The Clear Action Gate™ is designed to eliminate these problems, enabling you to meet your objectives by increasing production, while decreasing labour and equipment costs.

Vortex® Clear Action Gate™ Features

- Self-Cleaning Action on Closure, No Material Build-Up
- Positive Seal Across the Valve to Atmosphere
- Smooth, Unobstructed Bore for Unrestricted Flow of Material
- Seal Protected from Blast Abrasion
- Accurate Metering of Materials with Optional Metering Controls
- Easy Installation and Maintenance



Valve Specifications

Size/Bore Options	150mm to 400mm Diameters
Media	Powder, Pellets, Granulars
Connection Options	SVC Standard Stud Pattern, ANSI, DIN, JIS, Custom Flanges Available
Media Temperature	Up to 121°F continuous to 149°F intermittent service
Media Pressure	Up to 15 psig, -0.1 MPa +0.1 MPa, 1 barg, depending on size
Metal Construction Options	304 or 316L Stainless Steel, or Aluminium
Seal/Seat Material Options	Nylon, PET, Natural Rubber, and/or Silicon
Drive/Actuation Options	Double Acting Air Cylinder and Solenoid Operated Air Control Valve, Electric Actuator, Hand Crank
Position Confirmation	Magnetic Reed Switch, Proximity Switch, or Mechanical Switch
Compliance/Approvals	CE, ATEX, FDA
Industry Use	Plastics, Petrochemicals, Chemicals, Foods, Minerals, Textiles, Agriculture



Patent No. 4938250

Application Specific Modifications

S	Material contact is 316L stainless steel.
MG	Air cylinder has a magnetic ring which activates a magnetic reed position indicating switch.
GP	Internal welds and surfaces are ground and polished.
P	The gate inlet and outlet have 7 gauge flanges with bolt pattern to match a #125/150 ANSI bolt pattern
WS1	Gate Slide Blade is electro-polished. Polyethylene Terephthalate (PET) dust seals are used to replace Nylon.



VORTEX® CLEAR ACTION GATE™ DIMENSIONAL INFORMATION

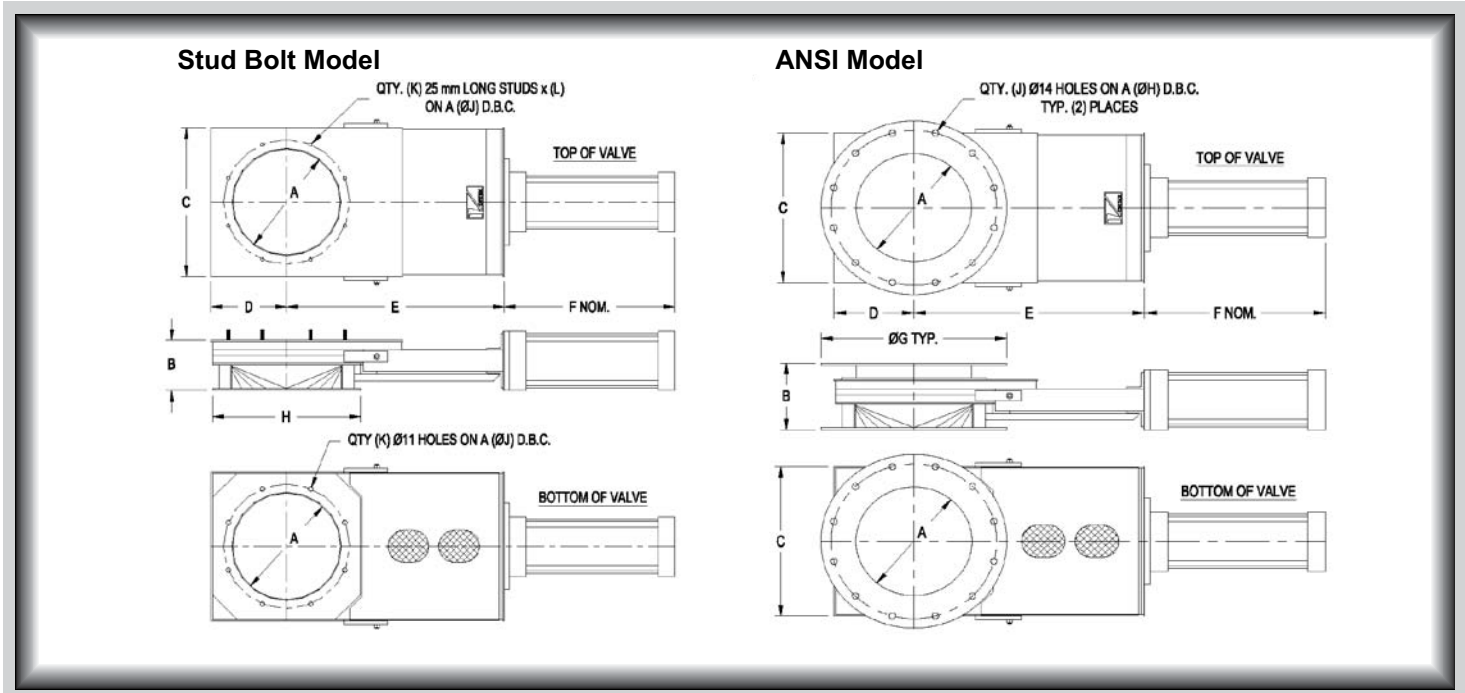

Stud Bolt Model	A	B	C	D	E	F	G	H	J	K	L	WT (kg)
JA06	149	95	248	124	352	295	152	241	191	8	5/16 UNC	25
JA08	200	95	298	149	429	346	203	292	241	8	5/16 UNC	30
JA10	251	117	349	175	505	419	254	343	292	8	5/16 UNC	34
JA12	302	137	400	200	581	476	305	394	351	12	5/16 UNC	41
JA14	352	149	451	225	657	521	356	445	402	12	3/8 UNC	59
JA16	403	162	495	248	737	578	406	495	457	16	3/8 UNC	75

ANSI Model	A	B	C	D	E	F	G	H	J	WT (kg)
JA06-P	149	133	248	124	352	292	279	241	8	27
JA08-P	200	133	298	149	429	343	343	298	8	32
JA10-P	251	156	349	175	505	419	406	362	12	36
JA12-P	302	162	400	200	581	476	483	432	12	45
JA14-P	352	184	451	225	657	521	533	476	12	64
JA16-P	403	200	495	248	737	578	597	540	16	82

All dimensions are in mm, Information subject to change without notice.