



Spencer Industravac Series B stationary model shown. Mobile models also available.

Performance Data

Volume (SCFM)	Vacuum (In. Hg)	Motor HP	Catalog Number		Shipping Weight (lb.)
			Stationary	Mobile	
300	8.0	15	SB-715B	PB-715B	1135
400	6.9	15	SB-615B	PB-615B	1125
420	4.9	10	SB-410B	PB-410B	1050
430	8.4	20	SB-720B	PB-720B	1160
520	5.7	15	SB-515B	PB-515B	1115
600	4.4	15	SB-415B	PB-415B	1105
610	6.1	20	SB-620B	PB-620B	1150

Performance based on 70 °F inlet temperature at sea level.

Materials of Construction

- Casing, separator, base, dirt can: ASTM A1011 hot-rolled steel
- Impellers: 5052-H34 aluminum
- Shaft: AISI-1045 hot-rolled bar steel
- Finish: epoxy primer with Spencer blue urethane topcoat

Product Features

Vacuum Producer

Multistage centrifugal
Standard overhung direct drive
6" tubing upblast exhaust (diffuser on mobile)
Average sound pressure level: 83 dBA at 3 ft.
Factory performance tested

Motor

10, 15 or 20 HP, 3500 rpm
208-230/460 or 575 volt, 3 phase, 60 Hz
Open drip-proof
Bearing life: 100,000 hours (L-10)

Separator

Tubular bag separator, shaker type: 30" diameter
Multiple inverted filter bags: Quantity 19
Filter bag area: 75 sq. ft.
Filter bag material: Cotton sateen (Part No. BVA90061)
Filter bag diameter: 5" (Cat. No. 5445-N)
External manual bag shaker
Large, hinged inspection door
Removable dirt can, cam actuated, capacity: 4½ cu. ft.
Average filtration efficiency: 99.9% at 3 microns
Axial inlets with target plate:
Stationary: primary inlet – 5" tubing with sleeve
secondary inlet – inlet valve (Part No. VLV90083) for 1½" diameter hose
Mobile: two inlet valves (Part No. VLV90083) for 1½" diameter hose

Base

Stationary: common frame with mounting pads
Mobile: large molded rubber tires
NEMA 1 across-the-line starter
50 ft. electrical cable

Available Options

TEFC and explosion-proof motors
Special motor voltages
NEMA 4, 7 and 9 starter enclosures
Grounded filter bags
Other filter bag materials
Dirt can liners (with equalizing line)
Discharge silencer
Discharge throttling valve
Inlet valve (Part No. VLV90100) for 2" diameter hose
4" threaded inlet to accommodate larger than 2" valve
Motorized bag shaker
Explosion relief vent
Rear primary inlet position

Stationary Model

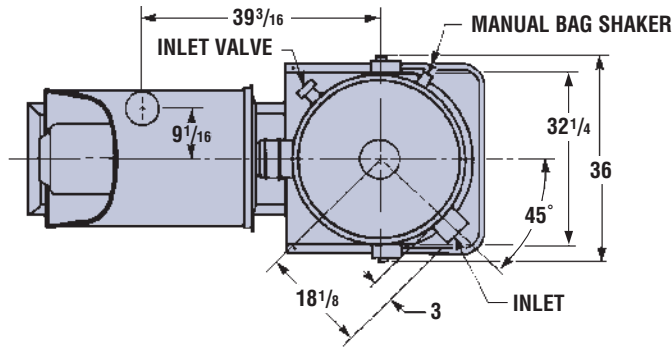

Mobile Model

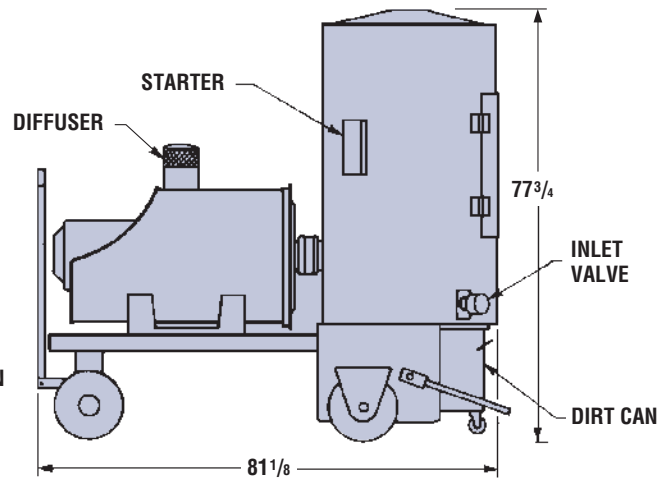
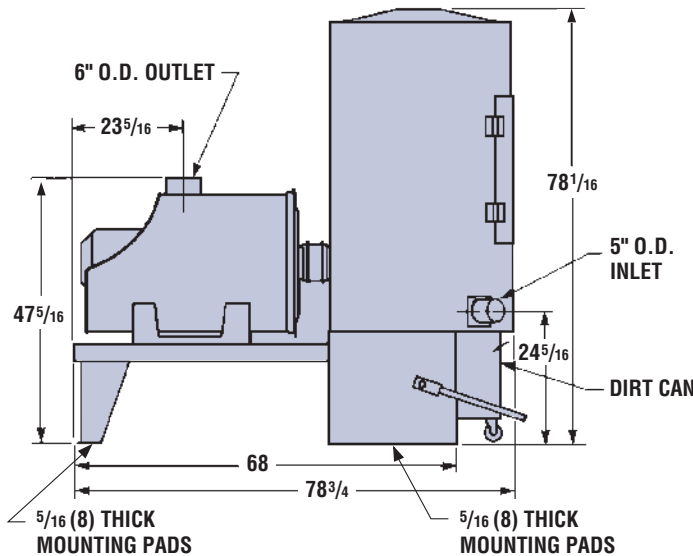
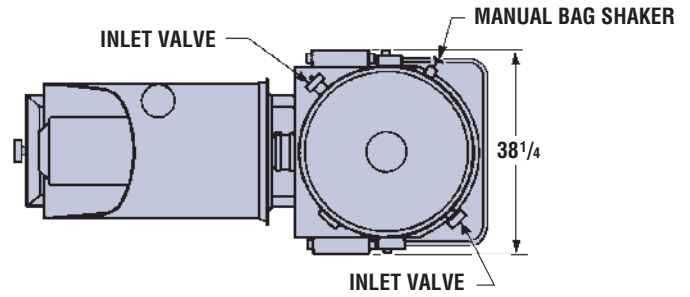

Performance Data	Motor Data	Separator Filter Data
Volume (SCFM) _____	HP _____ RPM _____	Area: 75 sq. ft. _____
Vacuum (In. Hg) _____	Voltage _____	Bag Quantity: 19 _____
Discharge Pressure (PSIA) _____	Phase _____ Hz _____	Bag Catalog No.: 5445-N _____
Inlet Temperature (°F) _____	Enclosure _____	Bag Material: _____

► Spencer may make improvements and dimensional changes to equipment designs based on market trends and requirements.

In Australia, for product selection and sales assistance, please contact:

Pneuvay Engineering
5-7 Louvain Street, North Coburg, Victoria Australia 3058
Freecall: 1800 786 642 ♦ Ph: +61 (03) 9350 6888
Fax: +61 (03) 9354 4365
Email: sales@pneuvay.com.au ♦ www.pneuvay.com.au



Industravac® is a registered trademark of The Spencer Turbine Company.

The  **Spencer** Turbine Company, 600 Day Hill Road, Windsor, CT 06095 USA

Blowers & Vacuum Systems with an Engineering Edge

TEL +1 860.688.8361 ♦ FAX +1 860.688.0098 ♦ www.spencerturbine.com

AU 294E Copyright ©2016 The Spencer Turbine Company Printed in USA 020116KBA

