

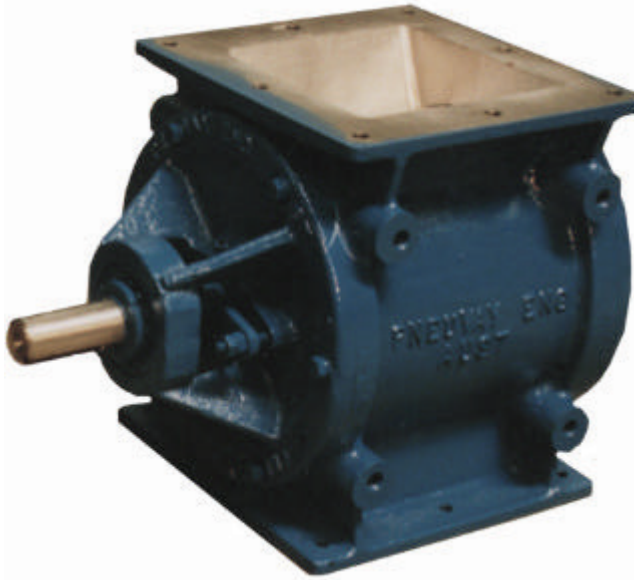

Rotary Valves



*Photo shows a
Drop-Through
Rotary Valve an
RV300*

Pneuvay Engineering's Rotary Valves are ideal for regulating the flow of material from one chamber to another whilst maintaining a good airlock condition.

Main features include:

Minimum clearances at rotor tips and sides of body.

Good throat opening – efficient pocket filling.

Close manufacturing tolerances.

High quality.

Competitively priced.

Rotary Valves are used extensively in applications associated with pneumatic conveying and dust filtration as both of these applications require that air leakage is minimized and material is metered at an even, but often quick pace.

Pneuvay Engineering's rotary valves are designed to be used in either pressure or gravity systems. They are ideal for conveying most dry solids, granular materials, palletted and powdered materials.

Companies typically use rotary valves to meter materials from the outlets of silos, hoppers, cyclones, mixers, weighers and dust collectors.

Pneuvay Engineering's rotary valves generally consist of a cast iron body, adjustable stainless steel tips and outrigger bearings. They are generally supplied with a geared motor, but are also available as a bare shaft.

For use in sanitary conditions,

All components are also available in stainless steel.

In addition, Pneuvay Engineering's rotary valves are available in either drop through (standard), or blow through design. Some companies also request a shrouded mild steel rotor to further protect fine clearances from wearing.

When used with particularly abrasive materials, all contact surfaces on the rotary valves are treated with a tungsten-carbide hardening process.

Rotary Valve Models

Rotary Valves are available in both Drop-Through and Blow-Through Models.

**Drop
Through
Model (DT)**



**Blow
Through
Model (BT)**





Rotary Valve (Drop-Through) Dimensions

Model	Capacity at 100% Filling m3/rev	Required kW Standard Duty	Approx. Wt. (kg) (no motor)	A	B	C	D	E	F	G	H	Ø
RV200	0.0043	0.37	42	156	230	156	230	280	437	480	8	11
RV300	0.015	0.75	106	250	330	250	330	390	607	645	12	13
RV300x450	0.022	1.1	120	400	480	250	330	390	607	795	14	13
RV500	0.0645	2.2	220	450	575	400	525	600	1000	1320	20	18

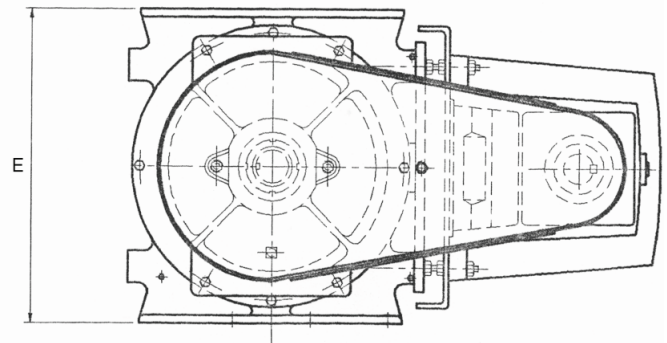
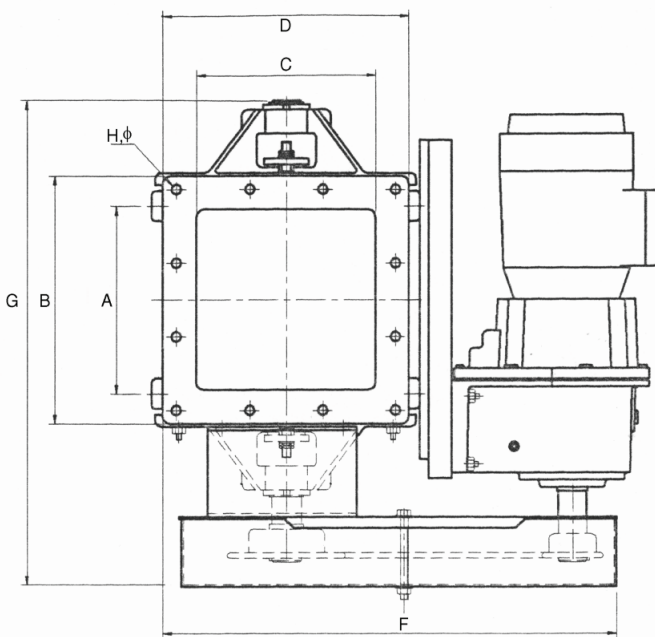

For more information regarding Rotary Valves or any other aspect of pneumatic conveying, please call Pneuvay Engineering

100mm Opening for RV 300 Pipe Connection (BT)

Dimensions

More information on blow-through styles and larger sizes available on request.

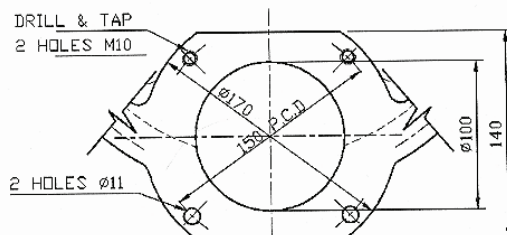

Model Number	A	B	C	D	E
RV200	N/A	70	96	110	M8
RV300	140	100	150	170	M10