



PNEUVAY
ENGINEERING PTY LTD

Pneuvay Engineering P/L
5 - 7 Louvain St, North Coburg, Victoria 3058, Australia
Tel: +61 3 9350 6888 Fax: +61 3 9354 4365
Freecall: 1800 786 642 www.pneuvay.com.au

Lump Breakers

Pneuvay Engineering's Lump Breakers provide an ideal way of removing unwanted lumps from many different products.

Lump Breakers allow manufacturers to ensure that their product is of a reliable, consistent texture.

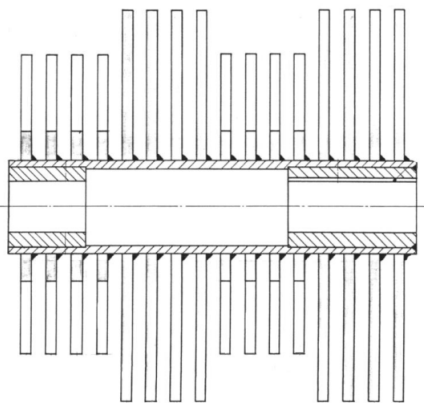
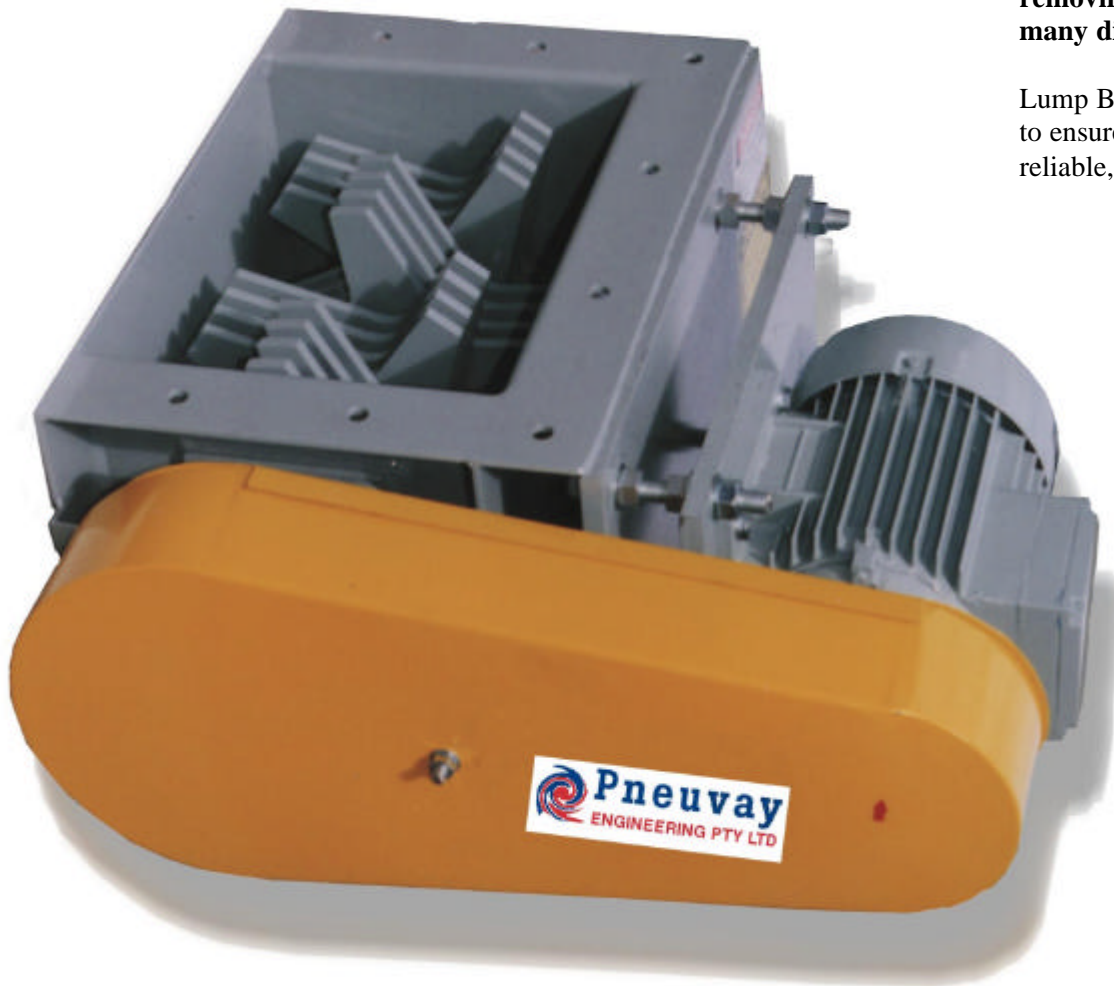

**Lump Breaker blades
and rotor
configuration**

Products suitable for use in a Lump Breaker include:

- ✓ Salt
- ✓ Feed and Grains
- ✓ Bones

They can be used in pneumatic conveying systems, and have proven to be very popular in reclaim systems within the food processing industry.

Suitable for light-medium duty, Pnevay's Lump Breakers are available in both mild, and stainless steel.



Lump Breaker Models

Lump Breakers are available in the following different models:

Model	A (mm)	B (mm) Approx	C (mm)	D (mm)	E (mm)	Power (kw)	RPM
LB 300x400	300	740	400	540	400	55	560
LB 400x400	400	870	400	540	400	75	320
LB 300x500	300	780	500	640	400	55	560
LB 400x500	400	890	500	640	400	75	320

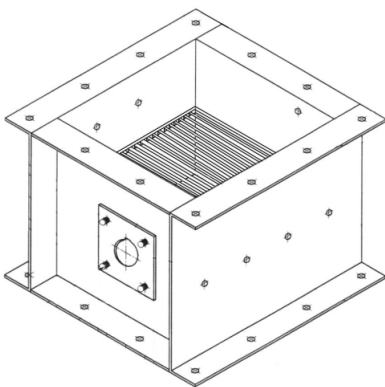

Lump Breaker body showing flanged ends and grill.

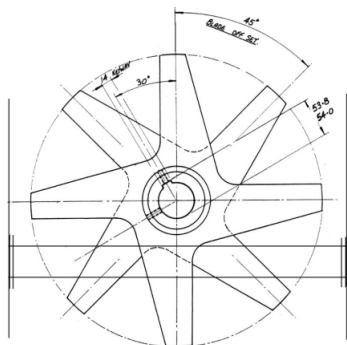
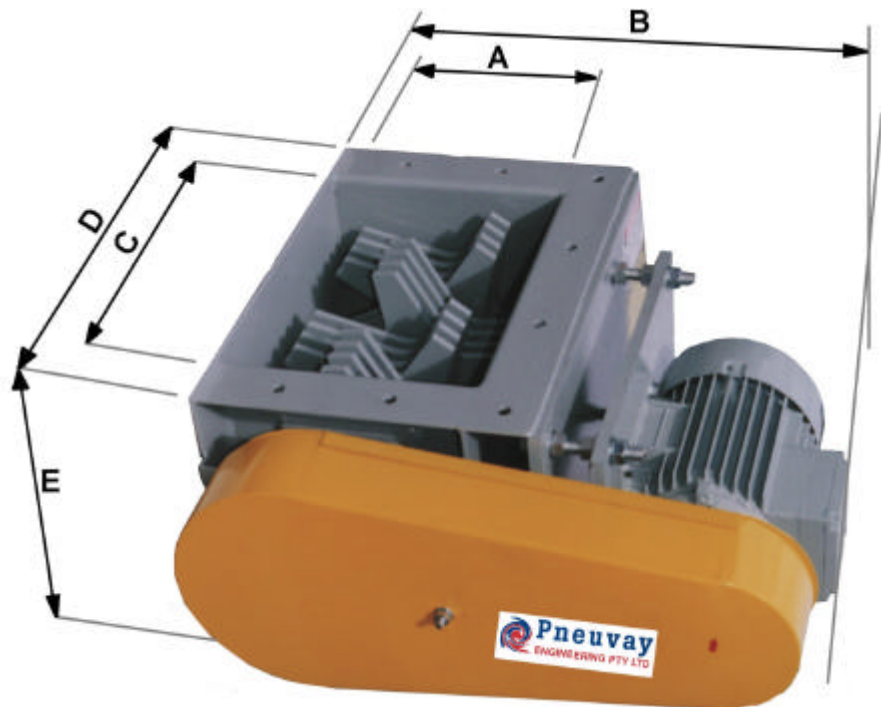

Lump Breaker blades configuration and impingement grill.

For more information regarding Lump Breakers or any other aspect of pneumatic conveying, please call Pneuvay Engineering.